

MODEL RED

DOWNBLAST DIRECT DRIVE CENTRIFUGAL ROOF EXHAUSTER

APPLICATION

Model RED direct drive units are used to exhaust air from all types of commercial and institutional buildings such as hospitals and health care facilities, schools, recreational buildings, machinery and equipment rooms, offices, retail stores and similar applications.

The nonoverloading wheel with its higher static pressure capability makes this unit suitable for either ducted or nonducted applications. It's roof mounting permits location near the area to be ventilated, allowing short duct runs and more efficient operation.

The spun aluminum exterior provides an attractive appearance and is compatible with belt driven Model DB and companion gravity units to make up a complete ventilation system. Direct drive units use smaller diameter wheels, resulting in low sound levels and quiet operation. They have no belts or fan bearings to maintain or adjust and consequently require very little maintenance.

CONSTRUCTION

Housing

- Curb cap has prepunched mounting holes for ease of installation.
- Fan plate isolates motor compartment from contaminated exhaust air.
- Spun aluminum hood and skirt for weather protection and attractive appearance.
- Heavy-gauge motor support for rigidity and strength
- Neoprene isolators for reduction of vibration and sound.
- Quick access to motor compartment for ease of maintenance.
- Conduit passage for easy electrical connection from below roof.
- Aluminum birdscreen and disconnect are included on standard models.

Centrifugal Wheel

- Non overloading for safe operation in ducted systems.
- Backward inclined wheels constructed of noncorrosive aluminum.
- Statically and dynamically balanced for smooth operation.

Speed Controllable Motors

- Standard motors are single speed, speed controllable and drip-proof.
- All motors are rated for continuous duty.
- Disconnect is standard with single speed drip-proof motors.
- Motors ship mounted as standard.

DIMENSIONAL DATA

MODEL RED	A	B	C	D	ROOF OPENING	Average Ship Wt. Lbs.
6	21 3/4	12	16 1/2	1 3/4	11 3/4	50
8	21 3/4	15 3/4	16 1/2	1 3/4	11 3/4	50
10	21 3/4	17 1/4	16 1/2	1 3/4	11 3/4	50
12	33 1/8	23 1/2	24	2	19 1/4	120
15	33 1/8	23 1/2	24	2	19 1/4	124

ACCESSORIES

MODEL RED	RECOMMENDED 12" HIGH MOUNTING CURB		RECOMMENDED GRAVITY DAMPER		DAMPER MOTOR (LOOSE)	115 VOLT SPEED CONTROL		230 VOLT SPEED CONTROL
	OD	STOCK NO.	OD	STOCK NO.	STOCK NO.	STOCK NO.	STOCK NO.	
6	14 3/4	611214 ●	11	411011 ●	411611 ●	2727.1 ●	N/A	3232.1 ♦
8	14 3/4	611214 ●	11	411011 ●	411611 ●	2727.1 ●	N/A	3232.1 ♦
10	14 3/4	611214 ●	11	411011 ●	411611 ●	2727.1 ●	N/A	3232.1 ♦
12	22 1/4	611222 ●	18	411018 ●	411611 ●	2727.1 ●	2828.1 ●	3232.1 ♦
15	22 1/4	611222 ●	18	411018 ●	411611 ●	N/A	2828.1 ●	3232.1 ♦

SPEED CONTROL 2727.1 MAX 1/3 HP-5 AMP 120V
2828.1 MAX 1/2 HP-10 AMP 120V



CENTRIFUGAL ROOF & WALL EXHAUSTERS

ACCESSORIES

Solid State Speed Control:

Control is matched to the motor and blower wheel to allow continuous reduction in performance allowing adjustments of airflow for system balancing. CFM is reduced in direct proportion to motor speed reduction. Speed control is only available for single phase. Exhauster performance can be controlled from the ventilated area.

AMCA SEAL



S&P USA Ventilation Systems, LLC., Div. of Soler & Palau Ventilation Group, certifies that the Models RED shown herein are licensed to bear the AMCA Seal. The ratings shown are based on test and procedures performed in accordance with AMCA Publication 211 and AMCA Publication 311 and comply with the requirement of the AMCA Certified Ratings Program.



LISTED POWER ROOF VENTILATOR
UL STANDARD 705

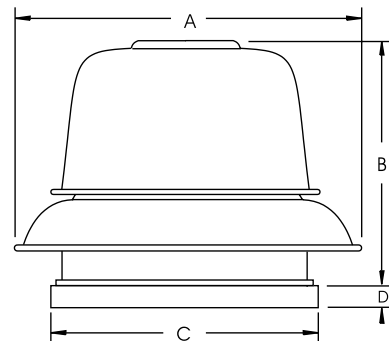

Ship Schedules:
● Next Day Shipment From Stock
▲ 3 Day Shipment From Stock
♦ 10 Day Shipment

ALL DIMENSIONS IN INCHES, WEIGHTS IN POUNDS. OD IS OUTSIDE DIMENSION OF SQUARE CURB AND DAMPER. DUE TO CONTINUING RESEARCH, S&P RESERVES THE RIGHT TO CHANGE SPECIFICATIONS WITHOUT NOTICE. Please refer to the General Catalog or contact the Factory for our Full Line of products available on standard shipping schedules.

MODEL RED					Downblast Direct Drive Centrifugal Roof Exhauster									Ventilator with Open Drip-proof Motor	
Model RED	Motor Hp	Max. BHP	RPM	Sones @ 1/8 SP	CFM at Static Pressure									115/1/60	208-230/1/60
					0	1/8	1/4	3/8	1/2	5/8	3/4	7/8	1	Stock No.	Stock No.
6	1/10	0.05	1650	8.0	390	347	295	232	134	-	-	-	-	RED06JH1AS ●	RED06JH1CS ♦
8	1/25	0.04	1050	4.5	573	468	326	-	-	-	-	-	-	RED08HM1AS ●	N/A
	1/10	0.12	1550	9.5	845	781	705	622	523	398	251	-	-	RED08JH1AS ●	RED08JH1CS ♦
10	1/4	0.27	1600	12.4	1436	1348	1256	1155	1041	910	766	604	412	RED10MH1AS ●	RED10MH1CS ♦
12	1/4	0.15	1150	8.9	1545	1356	1144	952	769	558	-	-	-	RED12MM1AS ●	RED12MM1CS ♦
	1/2	0.52	1750	18.3	2352	2226	2104	1973	1832	1689	1562	1443	1324	RED12QH1AS ●	RED12QH1CS ♦
15	1/2	0.46	1150	13.7	3003	2779	2540	2285	2038	1774	1480	1180	840	RED15QM1AS ●	RED15QM1CS ♦

Speed (RPM) shown is nominal. Performance is based on actual speed of test.

Performance certified is for installation type A-free inlet, free outlet.

Performance ratings include the effects of birdscreen in the airstream.

The sound ratings shown are the loudness values in the fan sones @ 5' (1.5m) in an hemispherical free field calculated per AMCA Standard 301.

Installation Type A: free inlet hemispherical sone levels.

Performance Data at Reduced Speed														
Model RED	Motor HP	Max. BHP	RPM	Sones @ 1/8 SP	CFM at Static Pressure									
					0	1/8	1/4	3/8	1/2	5/8	3/4	7/8	1	
6-1550	1/10	0.02	950	2.4	224	133	-	-	-	-	-	-	-	-
		0.02	1100	3.5	260	187	-	-	-	-	-	-	-	-
		0.03	1250	4.6	295	234	146	-	-	-	-	-	-	-
		0.04	1450	6.2	343	293	229	131	-	-	-	-	-	-
8-1050	1/25	0.02	750	1.8	409	238	-	-	-	-	-	-	-	
8-1550	1/10	0.05	1150	5.5	627	535	417	249	-	-	-	-	-	
		0.10	1450	8.4	791	721	638	545	425	276	-	-	-	
10-1625	1/4	0.06	900	4.2	808	640	403	-	-	-	-	-	-	
		0.09	1100	6.3	987	856	696	489	-	-	-	-	-	
		0.15	1300	8.5	1167	1058	936	790	615	405	-	-	-	
		0.22	1500	11.0	1346	1253	1152	1042	910	762	594	393	-	
12-1075	1/4	0.08	900	5.8	1209	959	708	456	-	-	-	-	-	
		0.12	1050	7.6	1411	1202	970	771	553	-	-	-	-	
12-1625	1/2	0.17	1200	9.6	1613	1432	1231	1040	866	678	442	-	-	
		0.24	1350	11.8	1814	1653	1484	1299	1139	984	821	633	376	
		0.36	1550	14.9	2083	1942	1801	1645	1484	1344	1210	1073	929	
15-1140	1/2	0.14	750	6.3	1958	1599	1212	759	-	-	-	-	-	
		0.19	850	7.9	2219	1907	1567	1203	795	-	-	-	-	
		0.27	950	9.7	2481	2202	1902	1602	1256	887	-	-	-	
		0.36	1050	11.5	2742	2493	2228	1950	1672	1352	1019	621	-	

Model in reduced speed table indicates size and motor RPM of base unit.

Performance is for that base unit operated at a reduced speed using the solid state speed control accessory.

AMCA Seal for sound rating does not apply to units with speed control.

Use 5 AMP Speed Control for motors 1/3 HP and smaller.

Use 10 AMP Speed Control for motors 1/2.